

R-LX-P-ZP Zinc plated Pan-Head Concrete Screw Anchor

Self-tapping concrete screwbolt

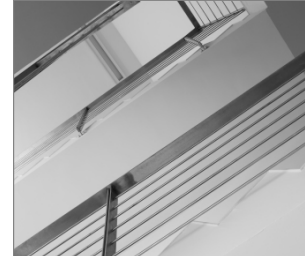

Product information

Features and benefits

- Time-efficient through-fixing installation with streamlined procedure - simply drill and drive.
- Completely removable with possibility of reuse
- Unique design with patented threadform ensures high performance for relatively small hole diameter
- Non-expansion functioning ensures low risk of damage to base material and makes R-LX ideal for installation near edges and adjacent anchors
- High performance in both uncracked and cracked concrete
- Different head types for any application
- Oversize head for fixtures with elongated holes
- Excellent product for temporary fixing
- Suitable for standard and reduced embedment depth

Applications

- Through-fixing
- Temporary anchorages
- Formwork support systems
- Balustrading & handrails
- Fencing & gates manufacturing and installation
- Racking systems
- Public seating
- Scaffolding

Base materials

Approved for use in:

- Cracked concrete C20/25-C50/60
- Non-cracked concrete C20/25-C50/60
- Hollow-core Slab C30/37-C50/60
- Reinforced concrete
- Unreinforced concrete

Also suitable for use in:

- Natural Stone (after site testing)

Installation guide



1. Drill the hole with rotary hammer drilling machine. Drill to a required depth.
2. Blow out dust at least 4 times with a hand pump.
3. Tighten the anchor to the fixture.
4. After installation a further turning of the screw must not be possible. The head of the screw must be in contact with the fixture and is not damaged.

Product information

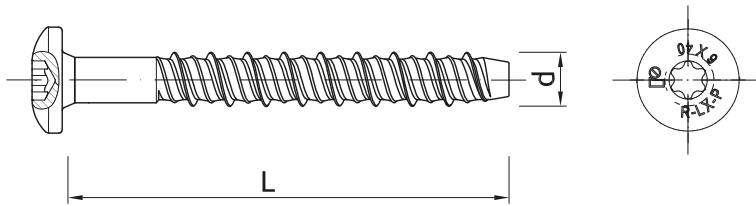

Size	Product Code	Anchor		Fixture		
		Diameter	Length	Max. thickness t_{fix} for:		Hole diameter
		d [mm]	L [mm]	$h_{nom,red}$ [mm]	$h_{nom,std}$ [mm]	d_f [mm]
6	R-LX-06X040-P-ZP	7.5	40	1	-	9

Installation data

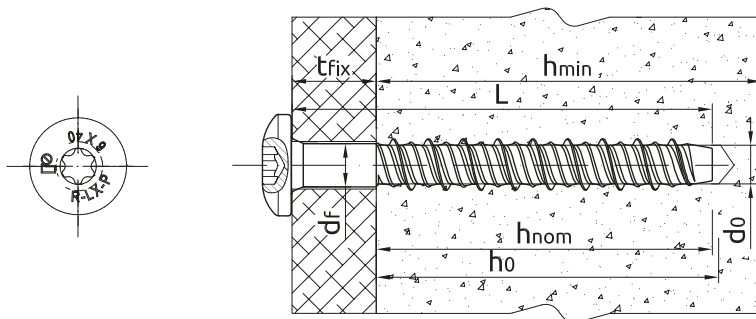

Normal concrete

Size	6		
Thread diameter	d	[mm]	7.5
Hole diameter in substrate	d_0	[mm]	6
Screw drive	-	[-]	T30
Head diameter		[mm]	14.6
Max. torque for impact screw driver	$T_{imp,max}$	[Nm]	400
REDUCED EMBEDMENT DEPTH			
Min. hole depth in substrate	$h_{0,r}$	[mm]	50
Real hole depth in substrate	h_0	[mm]	$L + 10 - t_{fix}$
Min. installation depth	$h_{nom,r}$	[mm]	39
Min. substrate thickness	$h_{min,r}$	[mm]	80
Min. spacing	$s_{min,r}$	[mm]	45
Min. edge distance	$c_{min,r}$	[mm]	45
MINIMUM EMBEDMENT DEPTH			
Min. hole depth in substrate	$h_{0,min}$	[mm]	45
Real hole depth in substrate	h_0	[mm]	$L + 10 - t_{fix}$
Min. installation depth	$h_{nom,min}$	[mm]	35
Min. substrate thickness	$h_{min,min}$	[mm]	80
Min. spacing	$s_{min,min}$	[mm]	45
Min. edge distance	$c_{min,min}$	[mm]	45

Installation data

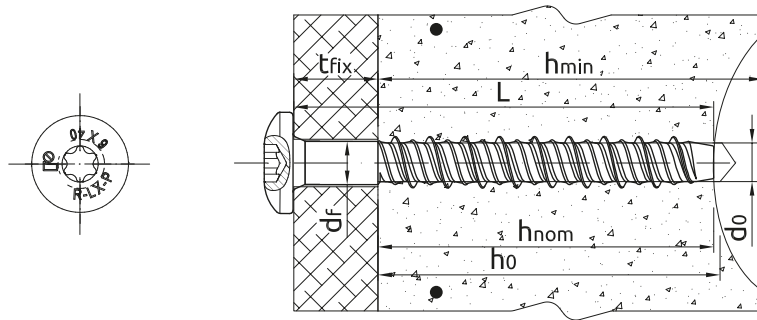

Hollow concrete slab

Size			6
Thread diameter	d	[mm]	7.5
Hole diameter in substrate	d ₀	[mm]	6
Screw drive	-	[-]	T30
Head diameter		[mm]	14.6
Max. torque for impact screw driver	T _{imp,max}	[Nm]	400
MINIMUM EMBEDMENT DEPTH			
Min. hole depth in substrate	h _{0,min}	[mm]	45
Real hole depth in substrate	h ₀	[mm]	L + 10 - t _{fix}
Min. installation depth	h _{nom,min}	[mm]	35
Minimum distance between anchor groups	a _{min,min}	[mm]	100
Min. spacing	s _{min,min}	[mm]	100
Min. edge distance	c _{min,min}	[mm]	100

Mechanical properties

Size			6
Nominal ultimate tensile strength - tension	F _{uk}	[N/mm ²]	1250
Nominal yield strength - tension	F _{yk}	[N/mm ²]	1100
Cross sectional area - tension	A _s	[mm ²]	28.3
Elastic section modulus	W _{el}	[mm ³]	21.2
Characteristic bending resistance	M ⁰ _{Rk,s}	[Nm]	31.8
Design bending resistance	M	[Nm]	21.2

Basic performance data

Performance data for single anchor without influence of edge distance and spacing

Size		6
CRACKED AND NON-CRACKED CONCRETE		
Reduced embedment depth h _{nom}	[mm]	39.00
Minimum embedment depth h _{nom}	[mm]	35.00
HOLLOW CORE SLAB		
Minimum embedment depth h _{nom}	[mm]	35.00
CHARACTERISTIC LOAD		
TENSION AND SHEAR LOAD F_{Rk}		
CRACKED AND NON-CRACKED CONCRETE		
Reduced embedment depth	[kN]	6.00
Minimum embedment depth	[kN]	3.00
HOLLOW CORE SLAB		
Minimum embedment depth	[kN]	6.00

Basic performance data

Size		6	
DESIGN LOAD			
TENSION AND SHEAR LOAD F_{rd}			
CRACKED AND NON-CRACKED CONCRETE			
Reduced embedment depth	[kN]	4.00	
Minimum embedment depth	[kN]	2.00	
HOLLOW CORE SLAB			
Minimum embedment depth	[kN]	4.00	
RECOMMENDED LOAD			
TENSION AND SHEAR LOAD F_{rec}			
CRACKED AND NON-CRACKED CONCRETE			
Reduced embedment depth	[kN]	2.85	
Minimum embedment depth	[kN]	1.42	
HOLLOW CORE SLAB			
Minimum embedment depth	[kN]	2.85	

Design performance data

Normal concrete

Size		6	
Min. installation depth	h_{nom} [mm]	35.00	39.00
Effective embedment depth	h_{ef} [mm]	24.70	30.00
TENSION AND SHEAR LOAD			
Characteristic resistance	F_{Rk} [kN]	3.00	6.00
Installation safety factor	V_{inst} -	1.00	1.00
Increasing factors for $N_{Rd,p}$ - C30/37	ψ_c -	1.00	1.08
Increasing factors for $N_{Rd,p}$ - C40/50	ψ_c -	1.00	1.15
Increasing factors for $N_{Rd,p}$ - C50/60	ψ_c -	1.00	1.19
Spacing	$s_{cr,N}$ -	100.0	90.00
Edge distance	$c_{cr,N}$ -	50.00	45.00
SHEAR LOAD			
STEEL FAILURE			
Characteristic resistance with lever arm	$M_{Rk,s}$ [Nm]	31.80	31.80
Partial safety factor	V_{Ms} -	1.50	1.50

Design performance data

Characteristic Resistance under fire exposure in concrete C20/25 to C50/60

Size			6
TENSION AND SHEAR LOAD			
Spacing	s_{cr}	[mm]	120.00
Edge distance	c_{cr}	[mm]	60.00
R (for EI) = 30 min			
Effective embedment depth	h_{ef}	[mm]	30.00
TENSION AND SHEAR LOAD			
Characteristic resistance	F_{Rk}	[kN]	0.28
R (for EI) = 60 min			
Effective embedment depth	h_{ef}	[mm]	30.00
TENSION AND SHEAR LOAD			
Characteristic resistance	F_{Rk}	[kN]	0.25
R (for EI) = 90 min			
Effective embedment depth	h_{ef}	[mm]	30.00
TENSION AND SHEAR LOAD			
Characteristic resistance	F_{Rk}	[kN]	0.20
R (for EI) = 120 min			
Effective embedment depth	h_{ef}	[mm]	30.00
TENSION AND SHEAR LOAD			
Characteristic resistance	F_{Rk}	[kN]	0.14

Hollow concrete slab

Size			6
Min. installation depth	h_{nom}	[mm]	35.00
Effective embedment depth	h_{ef}	[mm]	24.70
Min. bottom flange thickness	d_b	[mm]	35.00
TENSION AND SHEAR LOAD			
HOLLOW CONCRETE SLAB C30/37			
Characteristic resistance	F_{Rk}	[kN]	5.00
HOLLOW CONCRETE SLAB C40/50			
Characteristic resistance	F_{Rk}	[kN]	6.00
HOLLOW CONCRETE SLAB C50/60			
Characteristic resistance	F_{Rk}	[kN]	6.00
Installation safety factor	V_{inst}	-	1.00
Spacing	$s_{cr,N}$	[mm]	100.00
Edge distance	$c_{cr,N}$	[mm]	50.00
SHEAR LOAD			
STEEL FAILURE			
Characteristic resistance with lever arm	$M_{Rk,s}$	[Nm]	31.80
Partial safety factor	V_{Ms}	-	1.50

Product commercial data

Product Code	Anchor	Quantity [pcs]			Weight [kg]			Bar Codes
	Length [mm]	Box	Outer	Pallet	Box	Outer	Pallet	
R-LX-06X040-P-ZP	40	100	100	38400	1.29	1.29	525.4	5906675034546